

# Systemec

THE MULTI-FUNCTIONAL MACHINE



Sumitomo (SHI) Demag Plastics Machinery GmbH  
info-dpde@dpg.com  
www.sumitomo-shi-demag.eu





## Standard can be very special ...

...as special as the requirements of your customers. We understand and that is why the team of engineers at Sumitomo (SHI) Demag are committed to finding the solution – a machine generation that meets exactly this need for versatility.

As one of the leading technology providers and market players, we cater to customers in all major global markets with high-performance, cost-efficient and reliable injection moulding technology. We have delivered more than 100,000 injection moulding machines.

The Systec injection moulding machine is our all-rounder. With its modular system, it can be adapted to suit almost every project and has frequently proven to be the tailor-made, most practical and cost-efficient solution.

All components are finely tuned to provide an optimized machine specification. This potential allows a faster and more flexible response to market and customer requirements – no matter how special.



## Systec – Benefits at a glance

- Maximum versatility thanks to free configuration of the equipment range. Available in different expansion stages: from basic models with extensive equipment packages to complete production cells.
- Maximum energy efficiency and ruggedness thanks to toggle technology for machines 1,300 kN and above or fully-hydraulic operation for machines up to 1,200 kN.
- High production speed thanks to short dry cycle times and our activeQ active mould protection system, which does not interfere with the machine movements in the mould protection range.
- Linear guidance of the moving platen as standard ensures maximum precision, less wear on the mould and shorter cycle times.
- Very stiff machine base guarantees precise mould movements even at maximum mould weights.
- Energy-saving injection via DFEE pumps as standard. Optional upgrade to highly dynamic injection via servo valve or ultra-dynamic injection via position-controlled servo valve.
- Intuitive NC5 control with colour touch screen, specially configured for injection moulding processes. Standard user interface across the range.
- Extensive range of options and standardized automation solutions guarantee optimum individual production solutions to suit every requirement.

Systec – the multi-functional machine

## Fully hydraulic clamping system (350 kN - 1,200 kN)

### Fully hydraulic clamping system

with two short-stroke clamping cylinders ensures optimum clamp force transmission. A non-return valve provides positive locking and the quantity multiplier and the optimally adapted variable-volume pump generate high-speed precision movements

### Linear guidance as standard

on the moving platen ensures maximum precision, less wear on the mould and shorter cycle times

### Intuitive NC5 control

with process-oriented user interface for comfortable setting, monitoring and documentation

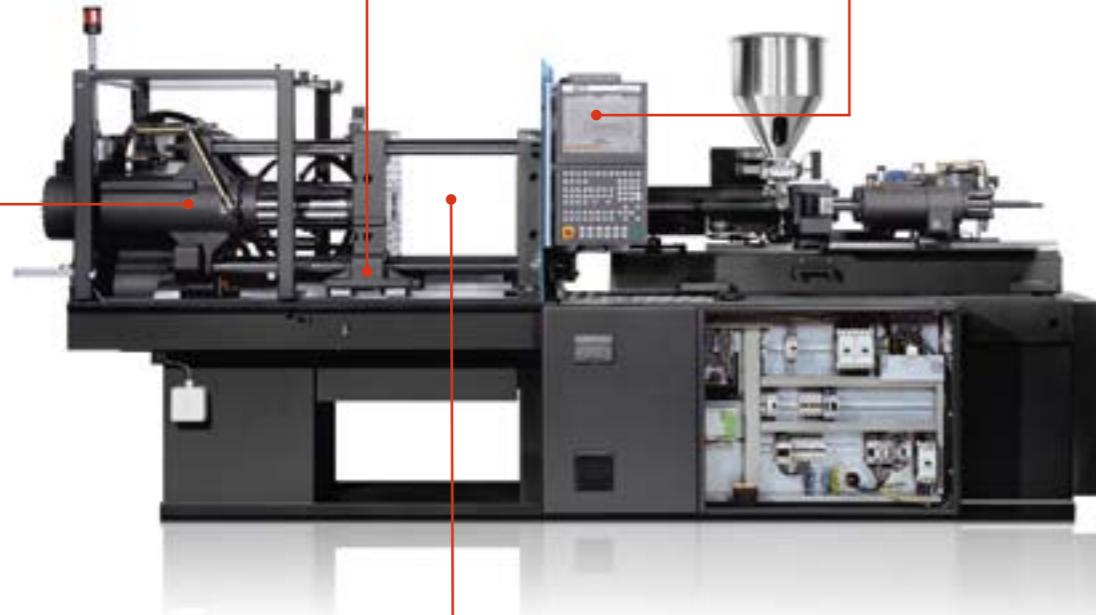

### Active mould protection

detects deviations across the entire closing stroke of the clamping unit. Active deceleration of the clamping unit reduces response time to a minimum (optional)

### Control of all moving axes

via NC5 control. Position measurement is carried out via non-contact, wear-free ultrasonic stroke measuring system

### Constant L/D ratio of the screw cylinders

(20:1 and 25:1) guarantees uniform melt quality, good colour dispersion and unproblematic changing of the injection cylinder

### Ergonomic arrangement

of the interfaces for mould and downstream equipment accelerates and facilitates product changes and mould installation

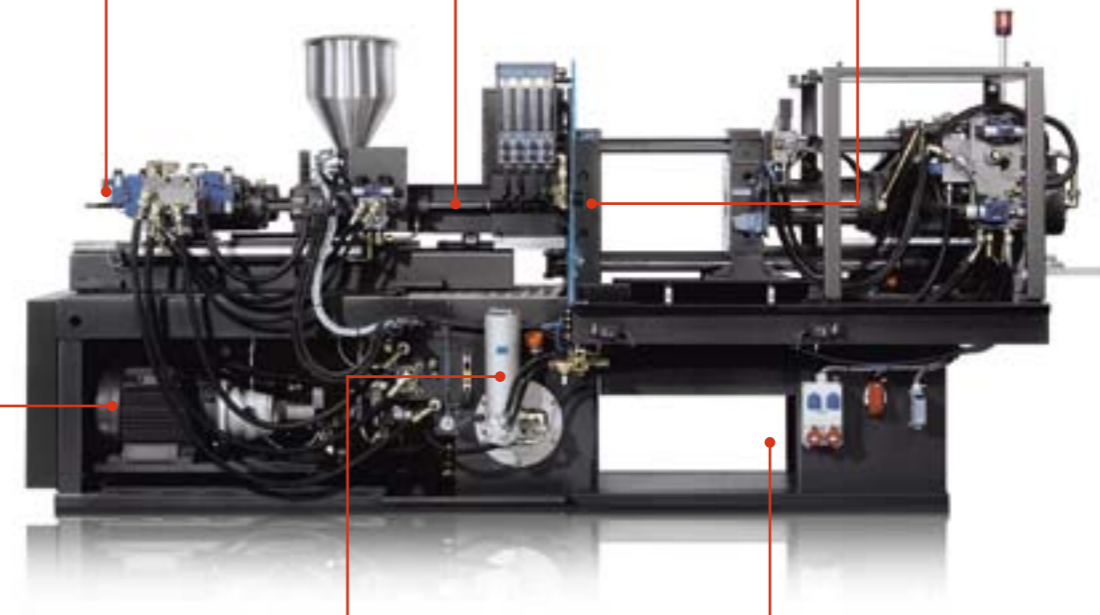

### DFEE centralized drive

provides high dynamics and repeatability. The DFEE pump only provides the required volume and meets the highest energy efficiency standards

### Independent filter and cooling system

activeCool&Clean stands for optimum quality and a long oil lifecycle. A separate low-pressure circuit allows optimum dirt deposition and heat transmission in the cooler. This warrants a long filter lifecycle and extends the oil change intervals to 40,000 operating hours

### Wide delivery chute, open on three sides

for flexible material flow and easy integration of the downstream components

## Toggle clamping system (1,300 kN - 10,000 kN)

### 5-point toggle

With optimized kinematics and computer-optimized deceleration and acceleration profiles provides maximum precision and energy efficiency

### Linear guidance as standard

on the moving platen ensures maximum precision, less wear on the mould and shorter cycle times

### Intuitive NC5 control

with process-oriented user interface for comfortable setting, monitoring and documentation

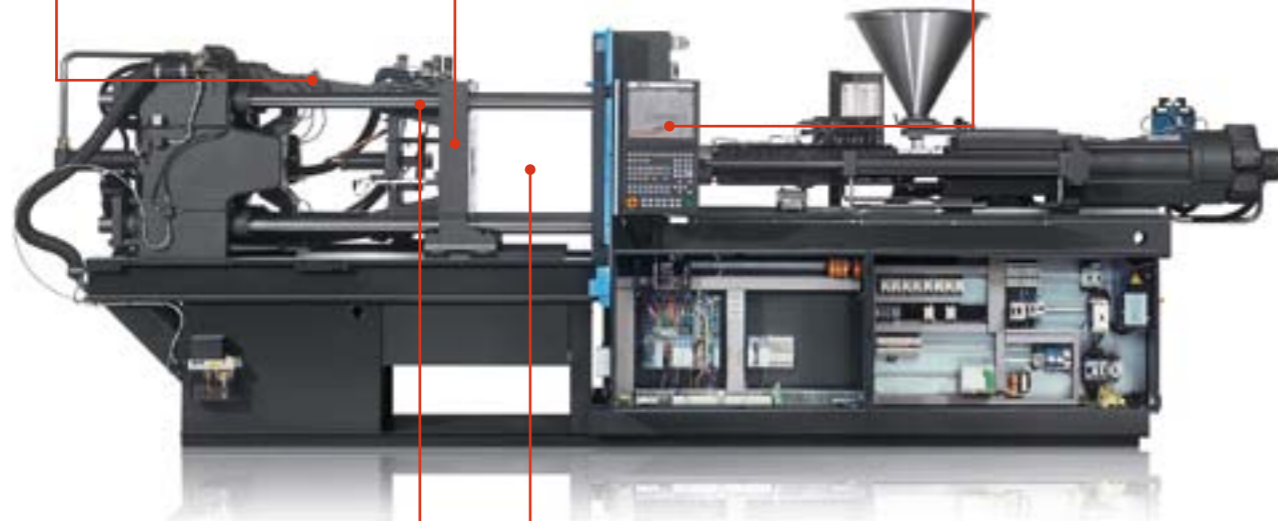

### Automatic tie bar puller

provides ample daylight for oversized moulds at the push of a button and allows lateral mould installation in production halls with low ceilings (optional)

### Active mould protection

detects deviations across the entire closing stroke of the clamping unit. Active deceleration of the clamping unit reduces response time to a minimum (optional)

### Control of all moving axes

via NC5 control. Position measurement is carried out via non-contact, wear-free ultrasonic stroke measuring system

### Constant L/D ratio of the screw cylinders

(20:1 and 25:1) guarantees uniform melt quality, good colour dispersion and unproblematic changing of the injection cylinder

### Guidance of the injection unit

on linear bearings ensures a high degree of precision

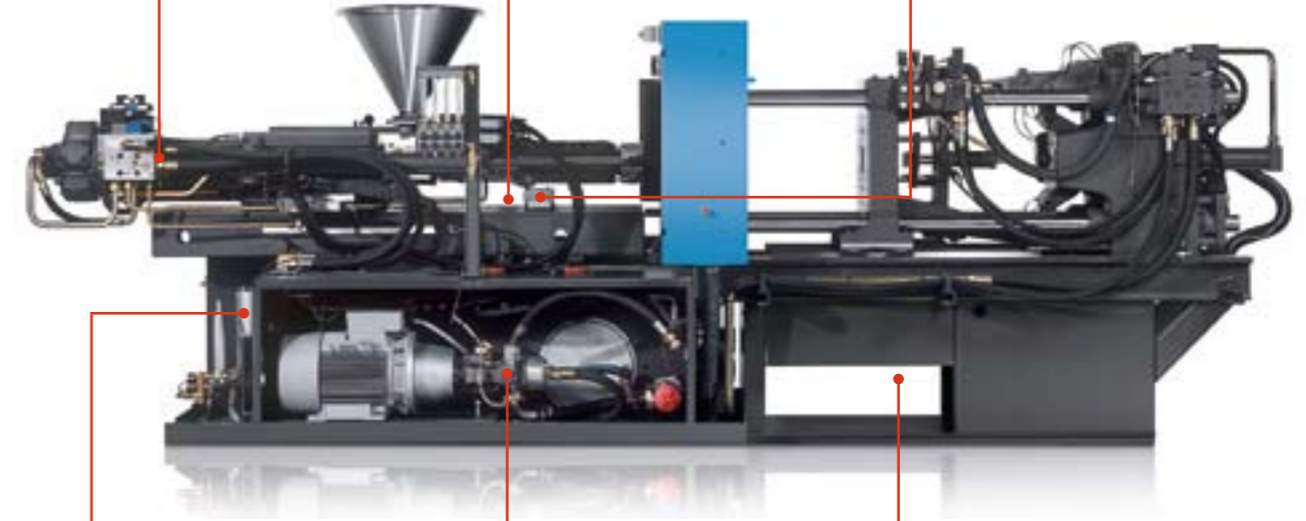

### Independent filter and cooling system

activeCool&Clean stands for optimum quality and a long oil lifecycle. A separate low-pressure circuit allows optimum dirt deposition and heat transmission in the cooler. This warrants a long filter lifecycle and extends the oil change intervals to 40,000 operating hours

### DFEE centralized drive

warrants high dynamics and repeatability. The DFEE pump only provides the required volume and meets the highest energy efficiency standards

### Wide delivery chute, open on three sides

for flexible material flow and easy integration of the downstream components

## Efficient production



Fig. 1: Fully hydraulic clamping unit

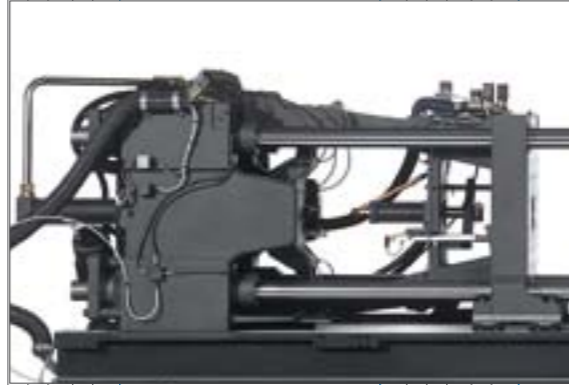

Fig. 2: Clamping unit with toggle



Fig. 3: Variable-volume pump



Fig. 4: Electric metering drive

## Dynamic, energy- and resource-efficient

### The clamping unit

The high travel speed of both the fully hydraulic and toggle clamp systems allows our customers to produce their parts in an extremely cost-efficient manner.

### Fully hydraulic systems (Fig.1)

with a maximum clamping force of 1,200 kN are operated via flow volume intensifier, which allows a high mould speed and dynamic startup and deceleration of the moving platen at a low installed pump capacity. Relatively low forces are required for mould movement, which means that the flow volume intensifier increases the oil flow volume by an order of twenty. This approach saves energy. During locking, the controller is disabled and the pump pressure ensures that the clamping force is safely applied directly via the clamping cylinder. A valve locks in the clamping force, with the result that no extra energy is required for maintaining the clamping force during the cooling phase.

### Toggle systems (Fig.2)

The toggle clamp systems for clamping forces from 1,300 kN up to 10,000 kN are designed to provide ideal kinematics for injection moulding machines. During movement, positive velocity transmission provides high speed but requires only a low amount of driving power. Platen contact and the build-up of clamping force takes place within the range of mechanical force amplification, which further reduces the amount of required driving power. The highly dynamic and energy-efficient toggle drive system also offers a beneficial self-locking mechanism. No additional energy is required during the entire cooling phase.

### Pump drive (Fig.3)

A pressure and flow-controlled variable-delivery pump is the heart of Systec machines. Its benefits are high dynamics in its variable delivery of both pressure and oil volume and its impressive energy efficiency. Oil flow or pressure is only delivered according to machine requirements.

Electro-hydraulic pressure and flow controlled DFEE pumps are available as single-circuit models with various capacity stages according to clamping force category and with dual-circuit hydraulics. Dual-circuit hydraulics allows completely autonomous and therefore highly precise movements. The force and velocity of ejectors and cores can be controlled in parallel using freely programmable sequences.

### activeDrive

The activeDrive system is an enhancement of the DFEE variable-delivery based on tried-and-tested components. The dynamic power adjustment to all stages of the injection moulding cycle ensures optimum effectiveness and minimal loss, particularly in the partial-load operational range and in no-load operation. The combination of frequency-controlled electro motor and highly dynamic variable volume pump allows savings of between 10 - 50 % compared to standard hydraulic systems.

### Electric metering drive (Fig.4)

The drive for the metering unit accounts for most of the total energy consumed by an injection moulding machine. At the same time, even technically advanced hydro motors have a comparatively low efficiency. This drawback can be remedied by using an electric screw drive, which is available as an option. Direct drives without gears are suitable for a wide range of models. The efficiency of the main energy consumer metering drive can practically be redoubled. Isolating metering from all other machine movements provides potential for energy reduction and increasing the plasticizing capacity.

## Efficient production

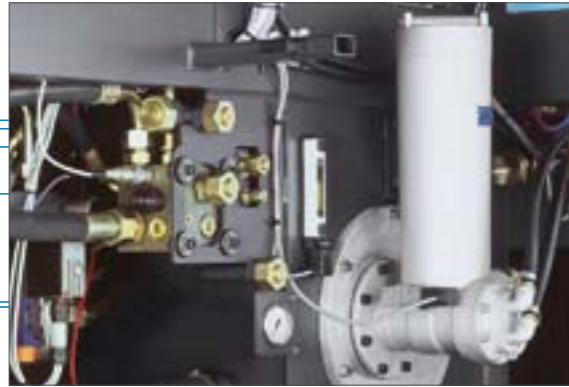

Fig. 5: active Cool&Clean



Fig. 6: activeEcon



Fig. 7: Linear guides

### Independent filter and cooling system activeCool&Clean (Fig.5)

Oil quality is one of the most important factors that affect process consistency and availability of injection moulding machines with hydraulic and hybrid drives. The activeCool&Clean system is our module for safe and maintenance-friendly operation of all Systec machines

This oil filter and cooling system operates in an independent secondary hydraulic circuit. The benefits are clear: an additional miniature pump passes the oil slowly and virtually pressure- and pulsation-free through an ultrafine filter with a downstream cooler. This approach delivers oil lifecycles of 40,000 hours.

For the entire production time, this system delivers oil with an impressive purity, which reduces wear on machine and equipment, reduces spare part costs and increases the machine's availability.

### Cylinder insulation

Optional cylinder insulation covers reduces energy loss due to heat emission from the plasticizing cylinder. This approach cuts energy costs and reduces the cylinder heat-up times. Shorter switching cycles extend the lifecycle of the heater bands and lower heat emission improves the ambient indoor temperature. The standard protection cover of the plasticizing cylinder is designed to allow the installation of insulating sleeves. If required, the insulation of individual cylinder sections can be removed at any time. Heating capacity reductions of between 15 - 40 % ensures a return on investment within one year.

### activeEcon (Fig.6)

A visual display of energy consumption is the first step towards optimized process settings. The activeEcon energy consumption analysis shows the influence of process settings on the machine's overall energy consumption. A before-and-after comparison helps moulders determine optimized machines settings. The program automatically calculates the effects of the optimized settings on the overall production costs.

## Precise and gentle on the mould

### Machine base and mould platens

An extremely solid machine base is the cornerstone of all Sumitomo (SHI) Demag machines. Accuracy, stability and minimum deflection of the machine base under high load are our main objectives. Thanks to its combination of stiff mould platens, parallel force transmission through the tie bars and standard linear guidance, the Systec offers high precision and gentle mould operation.

### Linear guidance as standard (Fig.7)

The linear guidance of the moving platen provides for minimal friction losses, due to the lubricant-free tie bar bushes, and perfectly parallel platens, even with heavy moulds. This technology stands for low energy consumption as well as for minimal mould wear and platen parallelism is between 30 and 50 % lower than the recommended Euromap value. This technology reduces both the energy consumption and wear on the mould.

### activeQ

In case of irregularities during mould closing, the integrated, highly sensitive activeQ mould protection system protects the mould from damage. Thanks to preventative maintenance, wear or insufficient lubrication of guide bolts or slides can be detected at an early stage. This is a real added value for the safety of your production.

## Modular system

Clamping force [kN]	Distance between tie bars [mm]	Injection units	Pump set [kW]	
			Single circuit	Dual circuit
350	320 x 320	35 / 80 / 120 / 200	7,5 / 11	15
500	370 x 370	80 / 120 / 200 / 310	11 / 15	18,5
600 / 800	420 x 420	120 / 200 / 310 / 430	15 / 18,5	22
1000	420 x 420	200 / 310 / 430 / 600	18,5 / 22	30
1200	470 x 470	200 / 310 / 430 / 600	22 / 30	30
1300	475 x 475	200 / 310 / 430 / 600	22 / 30	30
1600	520 x 520	310 / 430 / 600 / 840	22 / 30	30
2100	580 x 580	430 / 600 / 840 / 1450	30 / 37	37
2800	630 x 630	600 / 840 / 1450 / 2300	37 / 45	45
3500	720 x 720	600 / 840 / 1450 / 2300	45 / 55	55
4200	820 x 820	840 / 1450 / 2300 / 3300	45 / 55 / 75	55 / 75
5000	920 x 920	2300 / 3300 / 6400	45 / 55 / 75 / 90	55 / 75 / 90
6500	1020 x 1020	3300 / 6400 / 9500	75 / 90 / 110	90 / 110
8000	1120 x 1120	6400 / 9500	75 / 90 / 110	90 / 110
10000	1400 x 1120	6400 / 9500 / 11500 / 16000	75 / 90 / 110 / 165	90 / 165

## Modular options



### Plasticizing systems

With its optimized design, the three-section screw is ideal for processing a wide variety of applications. Our tailor-made plasticizing range comprised of screws with different L:D ratios with shearing and mixing sections, double-flighted screws and high-performance barrier screws provides solutions for every customer requirement. Moreover, Sumitomo (SHI) Demag offers durable plasticizing systems for abrasive or corrosive materials. If required, we also develop special customized solutions – our core competency.



### Servo valve

The Systec machine can be equipped with an additional fast-response servo valve, which allows highly dynamic control of injection and hold pressure. This approach provides a constant flow front velocity even for irregular wall thicknesses.



### Accumulator

The Systec easily delivers injection velocities of 600 mm/s with a 45 mm diameter screw. A highly efficient hydraulic accumulator is available for all machine sizes. It provides the required forward thrust for the screw. This module is ideal for the production of many packaging components and is distinguished by its excellent price/performance ratio.



### Electric screw drive

Machines with clamping forces of between 1,300 kN and 10,000 kN can be equipped with an optional electric metering drive. Compared to hydraulic drives, the electric system provides higher energy efficiency and is very profitable particularly for high-speed applications. As metering takes place at the same time as the opening and closing movement, this approach significantly reduces cycle times and provides a clear economic advantage.



## NC5 – The intuitive command centre

In all production process, the machine control is the most important HMI.

Hence, the standard NC5 control system for all machines is an essential part of Sumitomo (SHI) Demag's modular platform philosophy.

- The world connect remote maintenance module provides external access from trained experts.
- The optional module for connection to a central computer provides the connection to your production control centre.
- In "classic mode", the NC5 control system allows operators to change the screen back to the tabular mode of the former NC4 control. This way, operators can quickly familiarize themselves with the new system and save valuable time.
- The NC5 design's main objective is the visual display of the injection moulding process in an intuitive way, which allows easy touch screen control – this way, machine operation is made easy.
- User-defined screens, hot keys and the integrated control of peripheral equipment and special devices are additional highlights of the NC5 control system.
- Data and valuable process parameters are exchanged and stored via integrated USB interfaces.

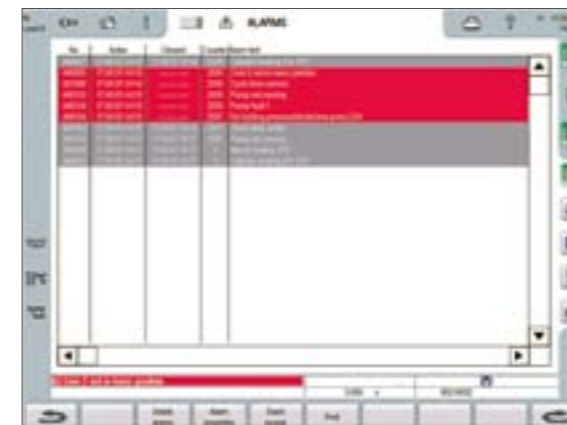

### Extended alarm functions

Apart from listing alarms, additional information is provided on possible causes of malfunctions. In respect of certain alarm groups, the operator can define in what way the machine should react to the alarm.



### Connecting additional peripherals

The new VNC technology allows the integration and operation of a variety of peripheral devices into the NC5 control system. The control of the peripheral device only needs to be connected to the NC5 control.

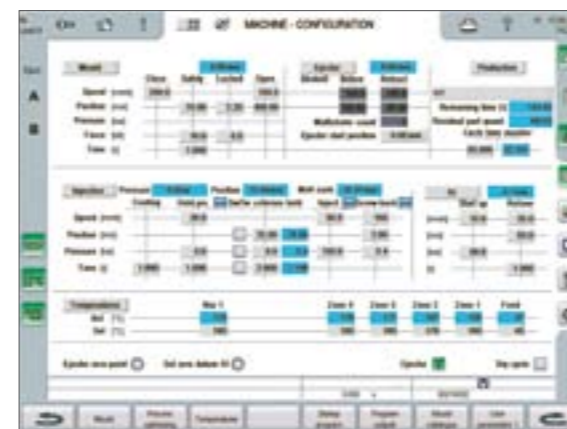

### Important process phases at a glance

The new page for machine settings provides a summary of important process phases and the specific parameters on one screen page. Any critical settings can be checked at a glance. Small graphic icons make it possible to transfer to the associated graphic operating screens.



### Documenting, printing, storing

The NC5 permits convenient management of machine settings and data such as data from the mould and handling devices or complete machine setting data, and their storage on any data carrier via USB interface. Where frequent product changes occur, this will save time and money. All quality-related process parameters can also be stored locally or transmitted to a central computer.



*Automotive –  
IMD application with multi-component technology:  
Ashtray cover*



*Packaging –  
Precise and repeatable with extensive mould  
protection: Shampoo bottle closure*



*Consumer –  
Flexible design:  
seat shell\**



*Automotive –  
Zero-defect production, just in time:  
car headlamp*

## The result counts...

...no matter what the project: the production of seat shells, covers or packaging parts. With Systec, a flexible response to market and customer requirements becomes a given. The machine is your reliable partner and provides you with maximum availability.

Highly flexible and readily expandable, the Systec ensures that you are ready for the future. Systec offers you flexibility and precision at the best price/performance ratio for all your projects, from surface finishing and optical parts right through to multi-component production.

Sumitomo (SHI) Demag supports you all over the world with services that are finely tuned to your requirements: from process-related consultancy and inspection right through to comprehensive maintenance. In the end, your result counts.